

The application examples are shown in simplified form. Complete part numbers are not provided for the recommended sensors since the exact model will vary from application to application. Our applications assistance group will help you to find the optimal solution.

Sensing size and contents of containers

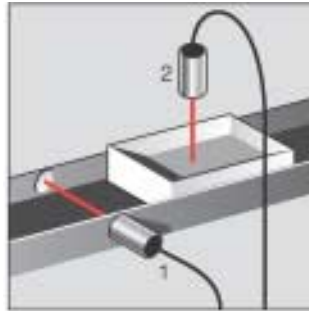

BOS 18M-...-1QB-... Retroreflective
 BOS R-1 Reflector
 BOS 18M-...-1HA-... Diffuse with HGA and adjustable switching distance

The retro-reflective sensor (1) indicates the presence of the box. Boxes can be counted or the length of a box determined (from the pulse duration). The diffuse sensor has background suppression (HGA) and its range is adjustable. It checks the contents of the boxes on the conveyor belt.

Sensing stack height

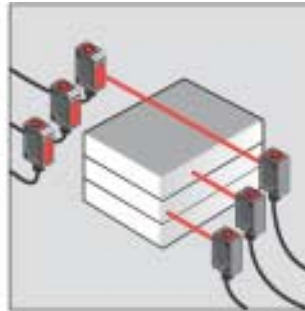

BLS 15K-... Emitter
 BLE 15K-... Receiver

Each thru-beam pair checks a certain stack height. Several sensors can be mounted over each other. The sensing distance can be up to several meters. The sensing accuracy in the vertical axis is just a few millimeters if the supplied apertures are used.

Guiding a moveable stage



BLE 18M-... Receiver
 BLS 18M-... Emitter
 BOS 18-BL-2 Slit aperture

The sensors are arranged so that the upper metal block breaks the light beam. When the block is removed for processing, the beam path is open. The sensor gives a signal, and the stage is automatically raised by the height of a block.



Sensing a read mark

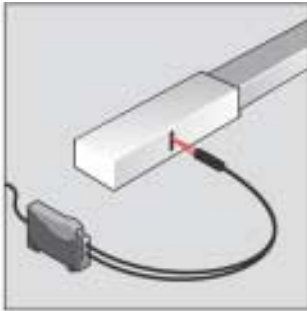

BOS 74K-... Base unit with adjustable sensing distance
BFO 74A-... Fiber optic cable

A marking (light band) on a dark background (belt, tube, container etc.) can be detected. Here a base unit for fiber optics and a plastic fiber optic cable are used.

Detecting a groove



BOS 18M-..-1PD-... Diffuse with adjustable sensing distance
BFO 18-... Fiber optic cable

To sense a groove on a bearing pillow, a diffuse sensor is adjusted with fiber optic cable so that the bearing pillow is always detected. The groove interrupts the beam (no reflection). The switch changes its output condition.

Drill break monitor

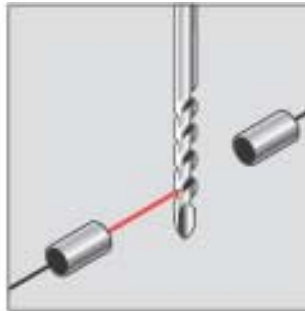

BLS 18M-... Emitter
BLE 18M-... Receiver
BOS 18-BL-2 Double slit diaphragm for thru-beams

Broken drill detection from a distance of 2 meters can be accomplished using a thru-beam system with double slit diaphragm. Drills larger than approx. 2 mm diameter can be checked. To detect even smaller drills (up to Ø 0.1 mm), use a laser thru-beam sensor.

Small parts detection

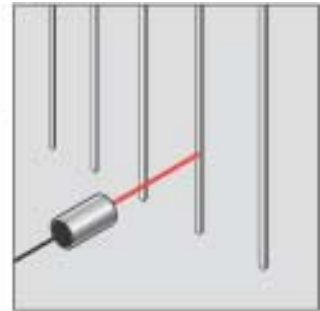

BOS 18M-... Diffuse with adjustable sensing distance
BOS 18-PK-1 Plano-convex lens
BOS 18M-..-1HA-... Diffuse with HGA

Detection of small parts while masking the background is done using a BOS 18-PK-1 optical adapter. For example, threads with a diameter of 0.1 mm could be sensed, whereby color is not a factor. The sensing range here is approx. 0...13 mm. Longer ranges can be achieved by using diffuse sensors with background suppression.

Level detection in transparent containers



BOS 18M-...-1PD-... Diffuse
BFO 18A-... Fiber optics

A diffuse sensor with fiber optic attachment is used as a thru-beam to monitor the level in a transparent container (cylinder). If there is no liquid at the height of the sensor, the light beam is not interrupted and instead arrives at the receiver. If the liquid is high enough, the light beam is deflected away from the receiver and the switch changes its state.

Differentiating various diameters

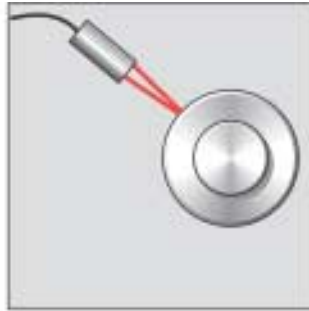

BOS 18M-...-1HA-... Diffuse with HGA and adjustable switching distance

To detect various shaft diameters, a diffuse sensor with background suppression (HGA) is calibrated so that it switches when the diameter is large. If a smaller diameter appears at the sensing station, this is interpreted as "background", and the sensor does not switch.

Checking contents of a package

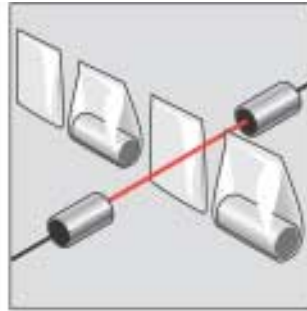

BLE 18M-... Receiver
BLS 18M-... Emitter
BOS 18-BL-1 Diaphragm for thru-beams

A thru-beam version is used to check the contents of the packaging. Emitter and receiver are arranged such that the light beam passes through the packaging. If the package is empty, the intensity is sufficient to illuminate the receiver. If however the packaging contains product, the contents interrupts this beam from the emitter and the switching output is activated.

Slack control

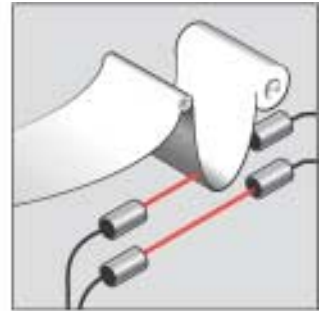

BLE 18M-... Receiver
BLS 18M-... Emitter

Two thru-beam sensors can be used to control the guiding of a roller conveyor. The thru-beams are arranged above each other so that at optimum slack the lower light beam is clear and the upper beam interrupted. If both light paths are clear, more roll tension is needed. If both are interrupted, there is too much material (slack) present.

Parts positioning

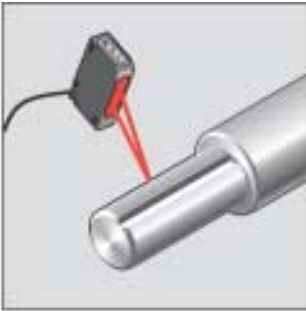

BOS 26K-...-1LHB-... Laser sensor with HGA and adjustable switching distance

To position a turned part you can check for the presence of a slot. A laser sensor with background suppression is calibrated so that it recognizes the surface of the turned part. If the light beam strikes the slot, the light is reflected back to the sensor at a different angle. The switch recognizes this as a background signal and ignores it, i. e. changes its switching state.

Level control of granules in small packages

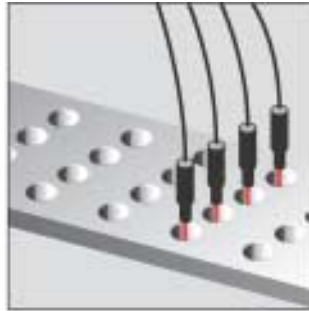

BOS 74K-.../ BOS 20K-... Opto sensor for plastic fiber optics cable
BFO 74A-.../ BFO D22-... Plastic fiber optics cable

A group of sensors monitors the contents of a whole row of small packets on a conveyor belt. The plastic fiber optics cable can be user-cut to the desired length. Standard supplied length is 2 meters.

Defect inspection of workpieces



BOS 74K-.../ BOS 15K-... Opto sensor for plastic fiber optics cable
BFO 74A-.../ BFO D22-... Plastic fiber optics cable

Multiple sensors with fiber optics attachments simultaneously check different features of a workpiece. Only if all holes, screws, tolerances and surface qualities are present, will the workpiece be accepted. Later failures and downtime are thus avoided.

Detecting a bead on a cam shaft

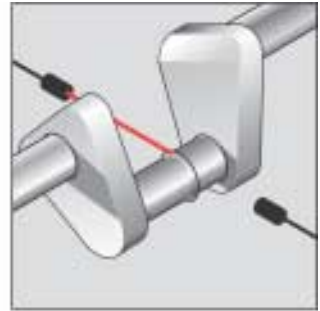

BOS 18M-...-1PD-... Diffuse with adjustable sensing distance
BFO 18-... Fiber optics cable

To determine whether a bead is present or not, a fiber optics attachment is used with a diffuse sensor. The fiber optic is arranged on a level parallel to the cam shaft. If a bead is present, the light beam is interrupted. With no bead, the beam path is free.

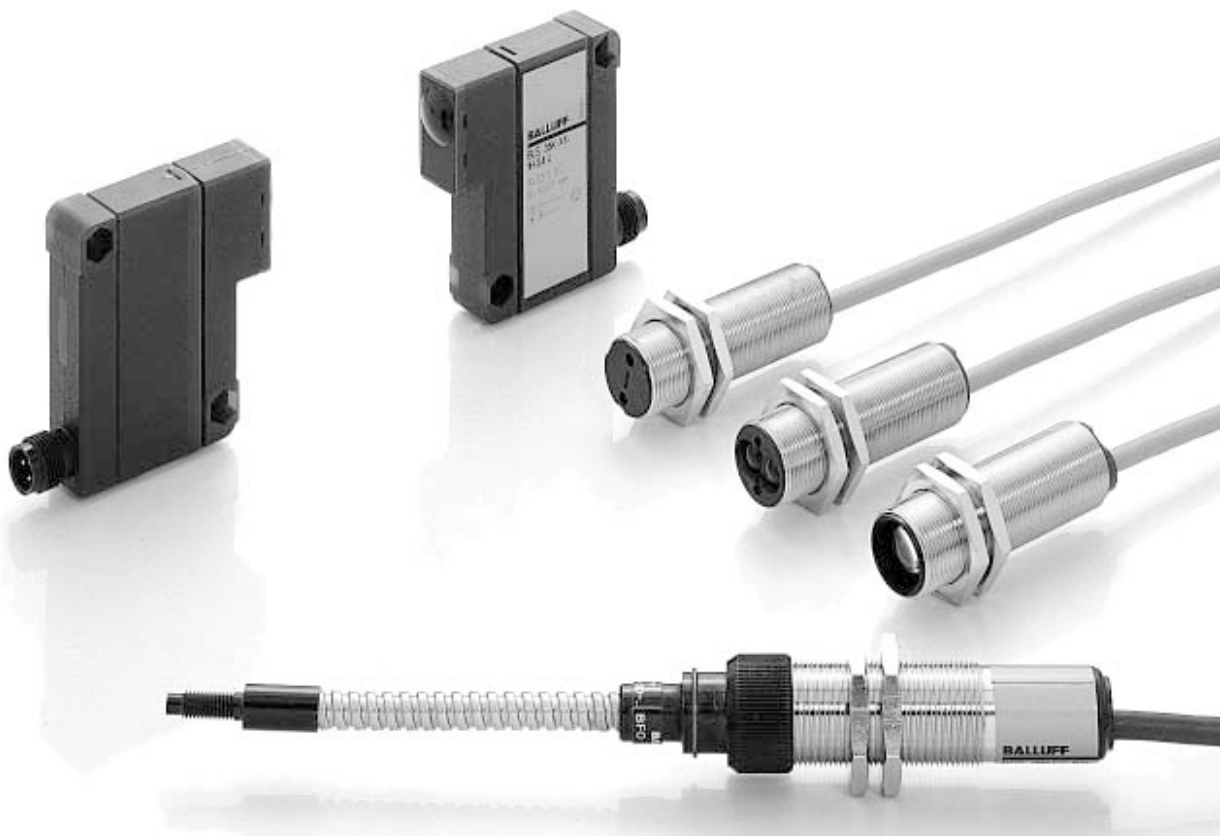

Part sorting

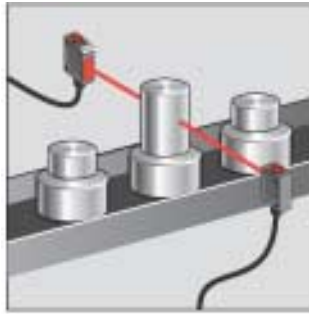

BLS 6K-...
BLE 6K-... Emitter
Receiver

To sort out parts which vary in height, a thru-beam sensor can be used. By pressing a button you can calibrate the BLS/BLE 6K so that the taller part interrupts the light beam and can be rejected. The teach-in procedure allows you to make this setting rapidly and adjust it to changing requirements.

Thread checking

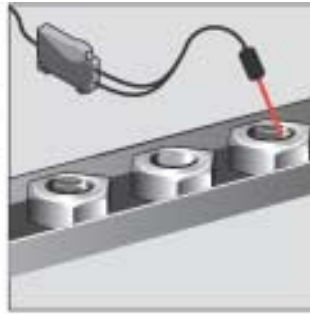

BOS 15K-.../
BOS 20K-.../
BOS 74K-... Basis unit
for plastic
fiber optics

Prior to assembling nuts, a check needs to be made to determine whether threads are present or not. If the threads are present, they will reflect the light back to the fiber optics and the sensor will switch. If no threads are present, total reflection will be created on the smooth wall of the hole and no light will be reflected back to the fiber optics; the sensor will not send a switching signal.

Packaging inspection

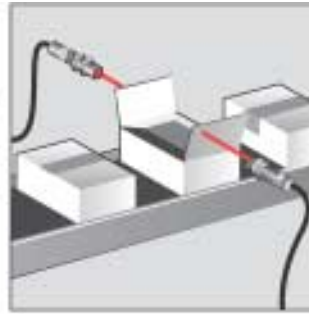

BLS 12M-... Emitter
BLE 12M-... Receiver

To check whether the packaging is correctly closed, a thru-beam sensor is configured so that the light path is just above the packaging. If the packaging is not correctly closed, the obstructing lid interrupts the light beam and the thru-beam sensor signals this.

**Counting
transparent bottles**



BOS 6K-... Retroreflective
with low
hysteresis

Reliable sensing of transparent objects, which absorb very little light, is best done using retroreflective sensors with low hysteresis. Using the BOS 6K with teach-in calibration you can even change the calibration setting while the process is running. It is no longer necessary to stop the process, since the sensors can for example be calibrated during the warm-up phase.

Circuit board inspection/ positioning

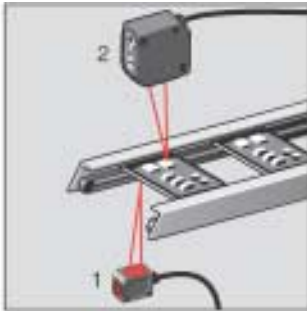

BOS 15K Diffuse focused
 BOS 26K Laser diffuse sensor with background suppression

To bring the circuit board to a particular inspection position, a focused diffuse sensor (1) is used. The circuit board crosses the light path of the sensor exactly at its focal point, thus enabling maximum precision. The small light spot from the laser diffuse sensor (2) and the background suppression can be used to check whether even small components are present on the board.

Final inspection: labels, caps

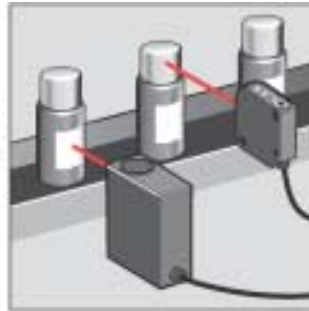

BKT Contrast sensor
 BOS 26K Diffuse with background suppression

As final inspection of dish detergent bottles a check must be made to determine whether the label and cap are attached. A contrast sensor is used for the label inspection. This distinguishes between the relative reflectivity of the label and the bottle. The cap is detected using a diffuse sensor with background suppression. Advantage of background suppression: if no cap is present, the threaded closure can be suppressed.

Checking seals

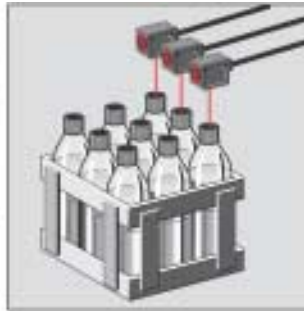

BOS 26K Diffuse with background suppression
 BOS 18M Diffuse with background suppression

Depending on installation circumstances and the required switching distance, a wide variety of diffuse sensors with background suppression can be employed. For tight mounting spaces the BOS 6K is ideal. If maximum resolution is required, the BOS 18M is the best choice; and if greater sensing range is needed, sensors from the series BOS 26K, BOS 36K or BOS 65K will solve the problem.

Checking for correct quantity

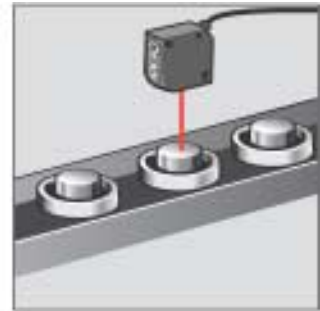

BOS 26K Diffuse with background suppression

Diffuse sensors with background suppression are used to check in detail whether an assembly process has been completed. These sense small objects with high precision and are not misled by different colors. Using laser sensors with HGA allows even finer details to be detected.

