

Graphic Operation Terminals

Human-Machine-Interface

Installation Manual

F920GOT-BBD5-K-E
F930GOT-BBD-K-E

About this Manual

The texts, illustrations, diagrams, and examples contained in this manual are intended exclusively as support material for the explanation, handling and operation of the graphic operation terminals F920GOT-BBD5-K-E and F930GOT-BBD-K-E.

If you have any questions concerning the programming and operation of the equipment described in this manual, please contact your relevant sales office or department (refer to back of cover).

Current information and answers to frequently asked questions are also available through the Internet (www.mitsubishi-automation.com).

MITSUBISHI ELECTRIC EUROPE B.V. reserves the right to change the specifications of its products and/or the contents of this manual at any time without prior notice.

Installation Manual Graphic Operation Terminals F920GOT-BBD5-K-E and F930GOT-BBD-K-E Article No.: 160242			
Version			Changes/Additions/Corrections
A	12/2004	pdp-dk	First Edition

Table of Contents

1	Introduction	
1.1	General Description	7
1.2	Connections	7
2	Specifications	
2.1	General Specifications	8
2.2	Specifications of the Operating Terminals	9
2.3	Dimensions and Panel-cutout	10
3	Description of the GOTs	
3.1	F920GOT-BBD5-K-E	11
3.2	F930GOT-BBD-K-E	12
3.2.1	Labeling the Function Keys	13
3.2.2	Pin Layout (F930GOT-K only)	13
4	Installation	
4.1	Preparing the Panel Surface	14
4.2	Mounting	15
5	Wiring	
5.1	Connection with the PLC	16
5.1.1	F920GOT-BBD5-K-E	16
5.1.2	F930GOT-BBD-K-E	18
5.2	Connection to a Personal Computer	21
5.3	Wiring of the Power Supply (F930GOT-K)	21
6	Start Up	
6.1	Data Transfer to the F920GOT	22
7	Maintenance	
7.1	Replacement of the battery (F930GOT-K only)	23

Safety Information

For qualified staff only

This manual is only intended for use by properly trained and qualified electrical technicians who are fully acquainted with automation technology safety standards. All work with the hardware described, including system design, installation, setup, maintenance, service and testing, may only be performed by trained electrical technicians with approved qualifications who are fully acquainted with the applicable automation technology safety standards and regulations.

Proper use of equipment

The graphic operation terminals F920GOT-BBD5-K-E and F930GOT-BBD-K-E are only intended for the specific applications explicitly described in this manual. Please take care to observe all the installation and operating parameters specified in the manual. All products are designed, manufactured, tested and documented in agreement with the safety regulations. Any modification of the hardware or software or disregarding of the safety warnings given in this manual or printed on the product can cause injury to persons or damage to equipment or other property. Only accessories and peripherals specifically approved by MITSUBISHI ELECTRIC may be used. Any other use or application of the products is deemed to be improper.

Relevant safety regulations

All safety and accident prevention regulations relevant to your specific application must be observed in the system design, installation, setup, maintenance, servicing and testing of these products. The regulations listed below are particularly important. This list does not claim to be complete; however, you are responsible for knowing and applying the regulations applicable to you.

- VDE Standards
 - VDE 0100
(Regulations for electrical installations with rated voltages up to 1,000V)
 - VDE 0105
(Operation of electrical installations)
 - VDE 0113
(Electrical systems with electronic equipment)
 - VDE 0160
(Configuration of electrical systems and electrical equipment)
 - VDE 0550/0551
(Regulations for transformers)
 - VDE 0700
(Safety of electrical appliances for household use and similar applications)
 - VDE 0860
(Safety regulations for mains-powered electronic appliances and their accessories for household use and similar applications)
- Fire prevention regulations
- Accident prevention regulations
 - VBG No. 4 (Electrical systems and equipment)

Safety warnings in this manual

In this manual special warnings that are important for the proper and safe use of the products are clearly identified as follows:



DANGER:

Personnel health and injury warnings. Failure to observe the precautions described here can result in serious health and injury hazards.



CAUTION:

Equipment and property damage warnings. Failure to observe the precautions described here can result in serious damage to the equipment or other property.

General safety information



CAUTION:

- ***Don't mount the graphic operation terminal in an environment that contains dust, soot, conductive or corrosive dusts, corrosive or flammable gas, or expose the unit to high temperatures, dew condensation or impact and vibration.***
- ***Make sure to press touch keys on the display screen with the hand only. Don't use excessive force. Don't use hard or sharp objects such as screw drivers or pens.***
- ***Don't bind the communication cable together with the main circuit, the power line or cables containing high voltages or currents. Keep a distance of at least 100 mm to these cables to prevent malfunction caused by noise.***



CAUTION:

- ***When the communication between the operation terminal and the PLC fails (e.g. caused by a cable breakage) it is impossible to operate keys or devices in the PLC via the GOT. After the error is gone the communication will be resumed. Make sure that a switch which gives a significant operation to the system is executed from any equipment other than the operation terminal and that there are no adverse consequences in the event of a communication failure. Emergency stops and other safety functions must not be controlled via the PLC.***
- ***Switch off the power supply before starting the installation or wiring.***

General safety information and precautions

The following safety precautions are intended as a general guideline for using the PLC together with other equipment. These precautions must always be observed in the design, installation and operation of all control systems.



CAUTION:

- *Observe all safety and accident prevention regulations applicable to your specific application. Installation, wiring and opening of the assemblies, components and devices may only be performed with all power supplies disconnected.*
- *Assemblies, components and devices must always be installed in a shockproof housing fitted with a proper cover and protective equipment.*
- *Devices with a permanent connection to the mains power supply must be integrated in the building installations with an all-pole disconnection switch and a suitable fuse.*
- *Check power cables and lines connected to the equipment regularly for breaks and insulation damage. If cable damage is found, immediately disconnect the equipment and the cables from the power supply and replace the defective cabling.*
- *Before using the equipment for the first time check that the power supply rating matches that of the local mains power.*
- *Residual current protective devices pursuant to DIN VDE Standard 0641 Parts 1-3 are not adequate on their own as protection against indirect contact for installations with positioning drive systems. Additional and/or other protection facilities are essential for such installations.*
- *EMERGENCY OFF facilities pursuant to EN 60204/IEC 204 VDE 0113 must remain fully operative at all times and in all control system operating modes. The EMERGENCY OFF facility reset function must be designed so that it cannot cause an uncontrolled or undefined restart.*
- *You must also implement hardware and software safety precautions to prevent the possibility of undefined control system states caused by signal line cable or core breaks.*
- *All relevant electrical and physical specifications must be strictly observed and maintained for all the modules in the installation.*

1 Introduction

This Installation Manual includes a brief summary of the main specifications of the graphic operation terminals F920GOT-BBD5-K-E and F930GOT-BBD-K-E, which should be sufficient to enable experienced users to install and configure the units. For further information on the operation terminals please refer to the manuals of the GOT F900 series. These manuals can be ordered or downloaded free of charge from the Mitsubishi website at "www.mitsubishi-automation.com".

1.1 General Description

The graphic operation terminals (GOT) F920GOT-BBD5-K-E and F930GOT-BBD-K-E (or F920GOT-K and F930GOT-K for short) are designed to be mounted in a panel or control cabinet. They are equipped with a high-resolution graphical display and a key pad with function keys and ten-keys for entering numeric values.

With the additional touch screen function of the F930GOT-K you can make inputs or control a machine easily by a touch of your hand.

The GOTs also offer diagnostic and monitor functions such as the display of the current value of PLC devices.

The screen creation software FX-PCS/DU-WIN-E (from version 2.7 onward) or GT-Designer (from version 5.26C) makes it easy to create user defined screens tailored to your application.

The build-in serial interfaces (RS422 and RS232C) of the operation terminals not only allow the connection to all types of MELSEC (Mitsubishi Electric) PLCs, but also to programmable logic controllers from third party manufacturers.

1.2 Connections

F920GOT-K

- Via the RS422 port:
 - direct connection to an PLC of the FX family (also to the interface adapters FX1N-422-BD and FX2N-422-BD) and to CPU modules of the MELSEC A and QnA series
- Via the RS232C-port:
 - direct connection to a CPU module of the MELSEC System Q

F930GOT-K

- Via the RS422 port:
 - Connection to the MELSEC FX range of PLCs (either direct or with an interface adapter FX1N-422-BD or FX2N-422-BD)
 - Connection to the MELSEC A and QnA series (either direct or via an interface module)
 - Connection to positioning modules FX2N-10/20GM
 - Connection to MITSUBISHI frequency converters of the S500, E500 or A500 series
 - Connection to PLCs from third party manufacturers
- Via the RS232C-port:
 - direct connection to a CPU module of the MELSEC System Q
 - Connection to a PLC of the MELSEC FX family via interface adapter FX□-232-BD or the active data interface module FX0N-232ADP
 - Connection to an interface module of the MELSEC A and QnA series, or the MELSEC System Q
 - Connection of a printer equipped with a serial RS232C port
 - Connection of a bar-code reader
 - Connection to PLCs from third party manufacturers

2 Specifications

2.1 General Specifications

CAUTION:

Please operate the Graphic Operation Terminal in the listed conditions only. If the GOT is used under other conditions, electric shock, fire, malfunction, damages or deterioration may be caused.

Item	Specifications					
Operating ambient temperature	0 to +50 °C					
Storage ambient temperature	-20 to +60 °C					
Ambient humidity for operation and storage	35 to 85 % relative humidity, non-condensing					
Vibration resistance	Conforms to IEC61131-2	Intermittent Vibration				
		Frequency	Acceleration	Amplitude (half)	Sweep count for X, Y, Z	
		10 to 57 Hz	—	0,075 mm	10 times (80 minutes in each direction)	
		57 to 150 Hz	9,8 m/s ² (1 g)	—		
		Continuous Vibration				
		10 to 57 Hz	—	0,035 mm		
		57 to 150 Hz	4,9 m/s ² (0,5 g)	—		
Shock resistance	Conforms to IEC61131-2, 147 m/s ² (15 g), 3 times in each direction X, Y und Z					
Noise immunity	1000 Vp-p tested by noise simulator, 1 μs at 30 to 100 Hz					
Dielectric withstand voltage	500 V AC > 1 min., tested between power terminals and ground (For F920GOT-BBD5-K-E only: between all power terminals of the PLC and ground terminal)					
Insulation resistance	5 MΩ at 500 V DC, tested between power terminals and ground (For F920GOT-BBD5-K-E only: between all power terminals of the PLC and ground terminal)					
Grounding	Class D grounding (Grounding resistance 100 Ω or less), If grounding is impossible, it can be omitted.					
Operating environment	No dust, soot, corrosive or conductive dust, corrosive or flammable gas					
Protection	IP65					

2.2 Specifications of the Operating Terminals

Item		F920GOT-BBD5-K-E	F930GOT-BBD-K-E
Supply voltage		5 V DC ($\pm 5\%$) (supplied from PLC via the data cable)	24 V DC (+10% / -15%), Ripple voltage 200 mV or less
Current consumption	Backlight ON	220 mA @ 5 V DC	220 mA @ 24 V DC
	Backlight OFF	180 mA @ 5 V DC	120 mA @ 24 V DC
Fuse		—	Build-in, irreplaceable
Allowable momentary power supply failure time		—	5 ms or less If less than 5 ms, the GOT will continue operation. If 5 ms or more, the GOT will shut down.
Backup of data	Clock data, Alarm history, Sampled data	—	By build-in FX _{2NC} -32BL lithium battery, Life: approximately 3 years, Guaranteed term: 1 year
	Screens	Screens are stored in the build-in flash memory and are not deleted even in the case of a cut down power supply and a low battery.	
Display	Type	STN monochrome liquid cristal (blue/white)	
	Size	60 mm x 30 mm 4 rows with 16 characters each	240 mm x 80 mm 5 rows with 30 characters each
	Resolution	128 x 64 dots	320 x 240 dots
	Dot pitch	0.47 mm x 0.47 mm	
	Life	approximately 50,000 hours at a operating temperature of 25 °C	
	Backlight	LED, white or red is selectable	Cold cathode tube
	Life of backlight	—	50,000 hours or more at a operating temperature of 25 °C Guaranteed term: 1 year
	Touch Keys	—	maximum 50 touch keys per screen
	Size of touch keys	—	15 x 4 dots
	Number of screens	max. 500 user created screens 30 system screens (No. 1001 to 1030)	
Key-pad	Overall number of key	26	28
	Function keys	6	8
	Ten-keys	12 (numbers 0 to 9, „-“ and „.“)	
	Other	8 (four keys for cursor movement and „SET“, „DEV“, „ESC“ and „ENT“ keys)	
User memory		Flash ROM 128 kB	Flash ROM 256 kB
Interfaces	RS422 (COM 0)	1 port (9-pin D-sub, female) for communication with PLC	
	RS232C (COM1)	1 port (9-pin D-sub, male) for communication with PLC and connection of a personal computer for data exchange	
LED indicators		—	One green LED in each function key
Acoustic indication		With build-in buzzer	
Weight		0.3 kg	0.6 kg

2.3 Dimensions and Panel-cutout

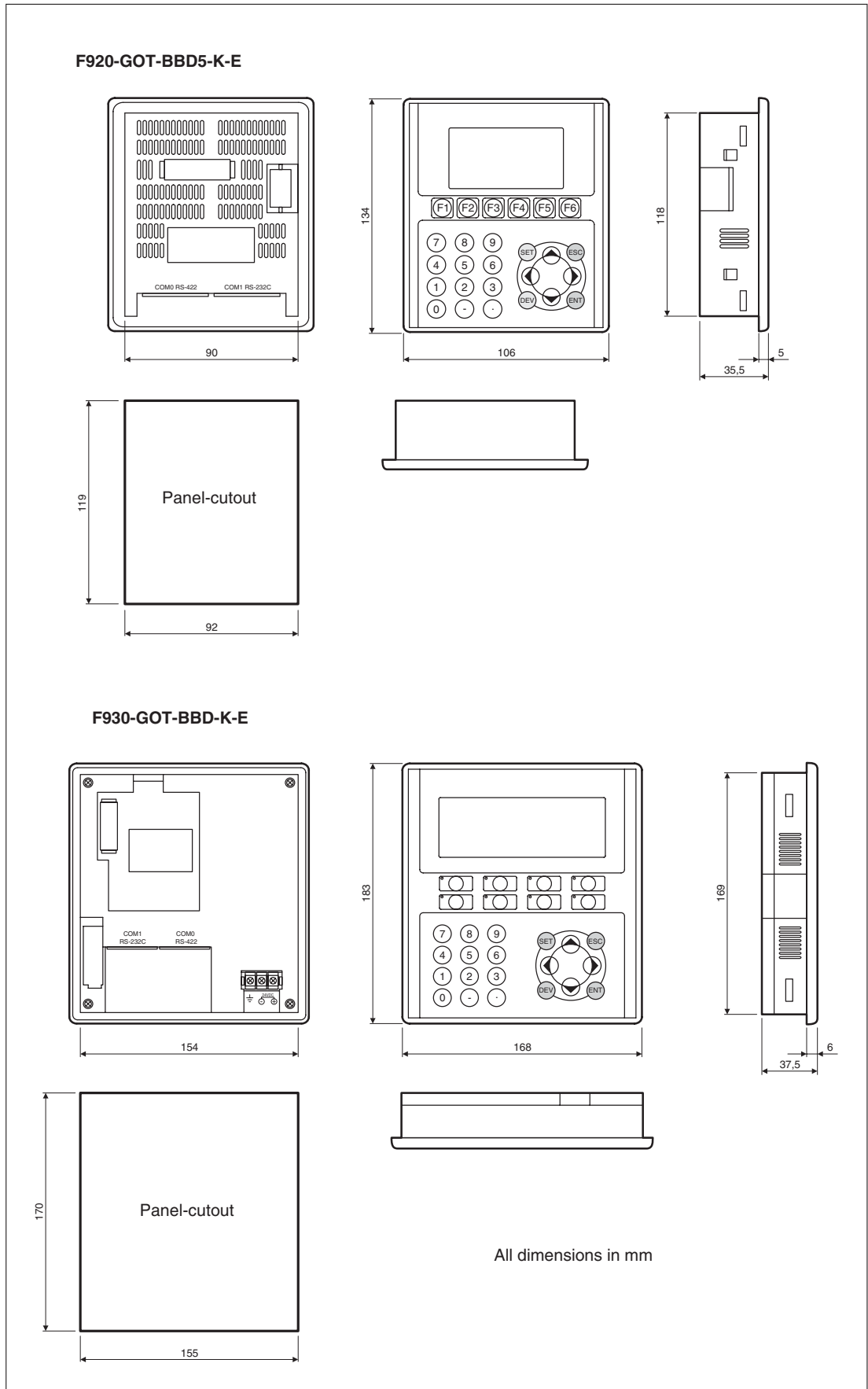

3 Description of the GOTs

3.1 F920GOT-BBD5-K-E

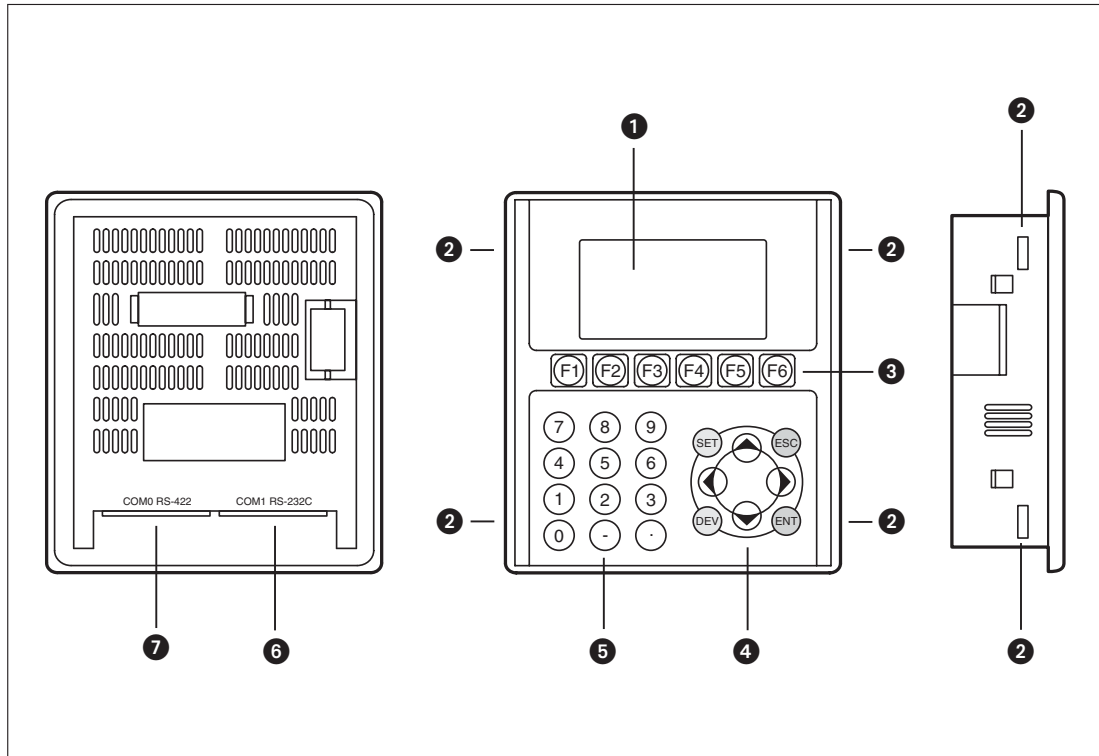

Number	Item	Description	
①	Display	Monochrome liquid cristal display (LCD)	
②	Slots for mounting brackets	Four mounting brackets (two on each side) are used to press the GOT from the backside of the panel against the panel-cutout.	
③	Function keys	No wiring is required for the function keys. They can be used in the program as normal inputs. The function of each key (push button or switch, set or reset, screen changing etc.) is specified in the software FX-PCS/DU-WIN-E or GT-Designer.	
④	Cursor keys		These keys move the cursor on a screen.
		„SET“	This key is used to display the cursor.
		„ESC“	<ul style="list-style-type: none"> To cancel an input operation To exit a system screen
		„ENT“	After pressing this key an input numeric value is taken over.
⑤	Ten-keys	„DEV“	<ul style="list-style-type: none"> Change over from user screens to system screens For entering devices on the system screen „DEVICE MONITOR“
		⑤	The keys 0 to 9, „-“ and „.“ are used to enter numeric values. The key „.“ changes the data format of the value between decimal and hexadecimal. The hexadecimal values „A“, „B“, „C“ ... and „F“ are entered with the keys „1“, „2“, „3“ ... and „6“ respectively.
⑥	RS232C port	<ul style="list-style-type: none"> Communication port for data transfer from a personal computer Serial port for connection to a PLC of the MELSEC System Q 	
⑦	RS422 port	Serial port for connection to a A, QnA, or FX series PLC	

3.2 F930GOT-BBD-K-E

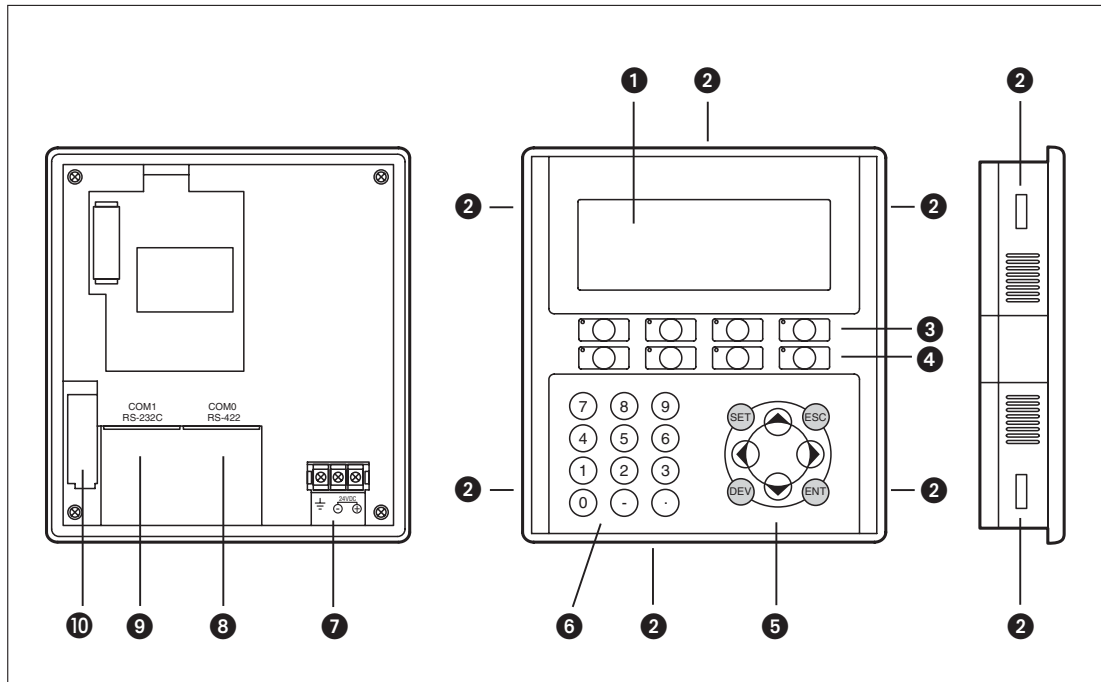

Number	Item	Description	
①	Display	Monochrome liquid cristal display (LCD) with touch-sensitive surface. That means that inputs can be made by touching the screen.	
②	Slots for mounting brackets	Six mounting brackets (two on each side and one on top and one on top and bottom) are used to press the GOT from the backside of the panel against the panel cutout.	
③	Function keys with LEDs	F1 to F4	
④		F5 to F8	
⑤	Cursor keys		These keys move the cursor on a screen.
		„SET“	This key is used to display the cursor.
		„ESC“	Use this key to cancel an input operation
		„ENT“	After pressing this key an input numeric value is taken over.
⑥	Ten-keys	„DEV“	For entering devices on the system screen „DEVICE MONITOR“
			The keys 0 to 9, „-“ and „*“ are used to enter numeric values. Other characters are entered on the touch screen.
⑦	Power supply terminals	The power supply (24 V DC) is connected to these screw terminals (M3).	
⑧	RS422 port	<ul style="list-style-type: none"> ● For connection to a PLC when the RS422 interface is used ● Connection to another operation terminal of the GOT series 	
⑨	RS232C port	<ul style="list-style-type: none"> ● Communication port for data transfer from a personal computer ● For connection to a PLC when the RS232C interface is used ● Connection to another GOT, a printer, or a bar-code reader 	
⑩	Battery compartment	A battery FX ₂ NC-32BL for backing up the clock and alarm data is mounted in this battery holder.	

3.2.1 Labeling the Function Keys

The function keys of the F930GOT-K can be labeled to suit the application. Insert the label from the rear of the GOT:

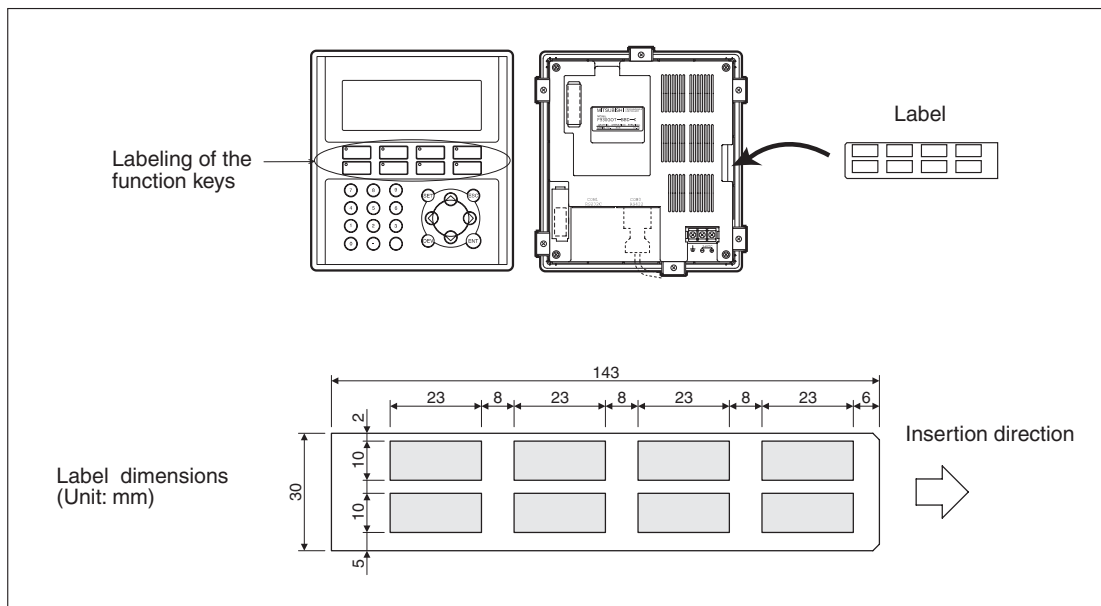

3.2.2 Pin Layout (F930GOT-K only)

RS232C (9-pin D-SUB, male)

PIN	Signal	Description	
1	NC	Not used	
2	RD (RXD)	Receive Data	
3	SD (TXD)	Transmit Data	
4	ER (DTR)	Data Terminal Ready	
5	SG (GND)	Ground	
6	DR (DSR)	Data Set Ready	
7	RS (RTS)	Request to Send	
8	CS (CTS)	Clear to Send	
9	—	Do not connect this pin.	

RS422 (9-pin D-SUB, female)

PIN	Signal	Description	
1	TXD+ (SDA)	Send Data A	
2	RXD+ (RDA)	Receive Data A	
3	RTS+ (RSA)	Request to Send A	
4	CTS+ (CSA)	Clear to Send A	
5	SG (GND)	Ground	
6	TXD- (SDB)	Send Data B	
7	RXD- (RDB)	Receive Data B	
8	RTS- (RSB)	Request to Send B	
9	CTS- (CSB)	Clear to Send B	

4 Installation

The operation terminals of the GOT F900 series are designed to be mounted in a control panel or the door of a control cabinet.

All mounting angles from 0° (horizontal, e. g. in an control panel) to 90° (vertical, e. g. in a door) are allowed, but the ambient temperature must kept below 50 °C.

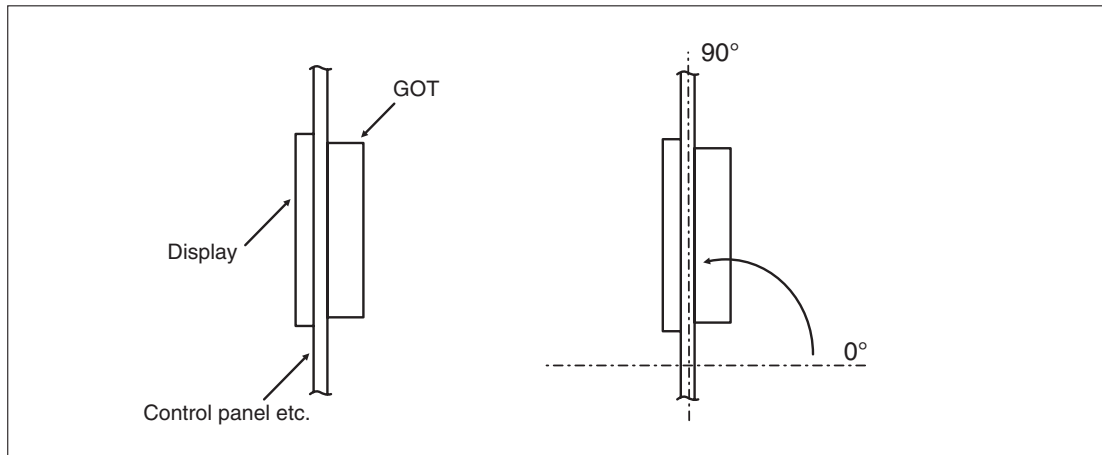

4.1 Preparing the Panel Surface

Cut a rectangular mounting hole in the panel surface with the dimensions shown on page 10. A space of approx. 10 mm is required inside the panel on each side of the cutout for the mounting brackets. There is no need for drilling additional holes for mounting the GOT. The maximum thickness of the panel surface is 5 mm.



CAUTION:

During mounting of the GOT make sure that no electric wire chips or cutting chips drop into the ventilation holes of the operating terminal.

4.2 Mounting

The GOT is fixed in the panel with the mounting brackets (four for the F920GOT-K, six for the F930GOT-K) delivered with the operation panel. Because no holes are needed for these fixings, they are invisible from the front.

- ① Attach the packing seal to the backside of the GOT.

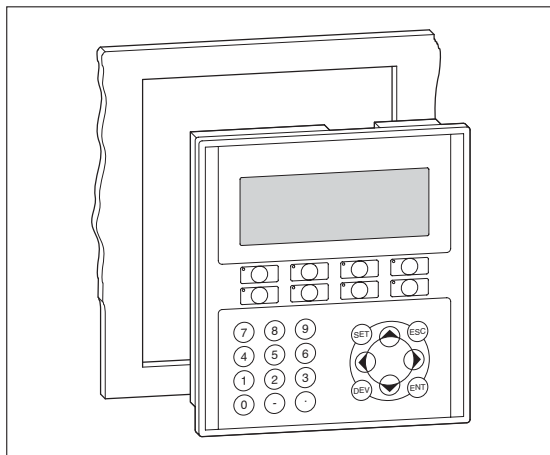

- ② Insert the GOT from the front of the panel into the cutout.

- ③ Hang the hook of the mounting brackets into the slots on the sides of the GOT. Use all supplied mounting brackets to prevent dust and moisture from creeping in.

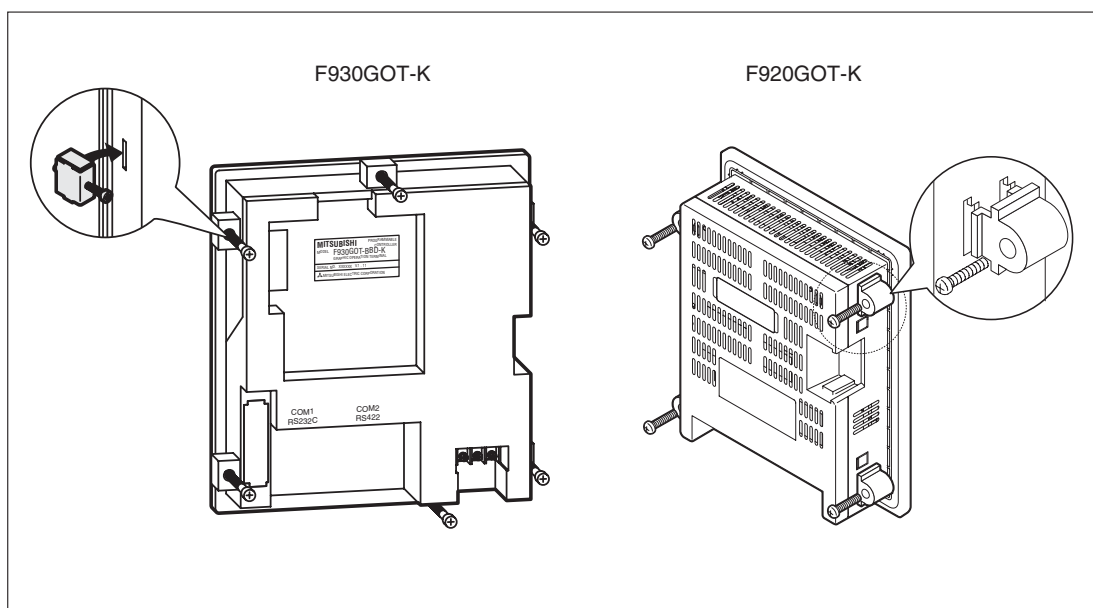

- ④ Tighten the screws of the mounting brackets just enough to fix the GOT.
 ⑤ Check the orientation of the display and the correct mounting of the packing seal.
 ⑥ Now tighten the screws of the mounting brackets until the GOT is securely fixed (tightening torque: 0.3 to 0.5 Nm).

5 Wiring

5.1 Connection with the PLC

5.1.1 F920GOT-BBD5-K-E



CAUTION:
 Do not connect a PLC to the RS422 port and at the same time a second PLC to the RS232C port of the GOT.
 Doing so can damage the GOT or the PLCs.

Connection to a CPU of the FX0, FX0S, FX0N, FX1S, FX1N, FX2N or FX2NC series, or the interface adapters FX1N-422-BD and FX2N-422-BD:

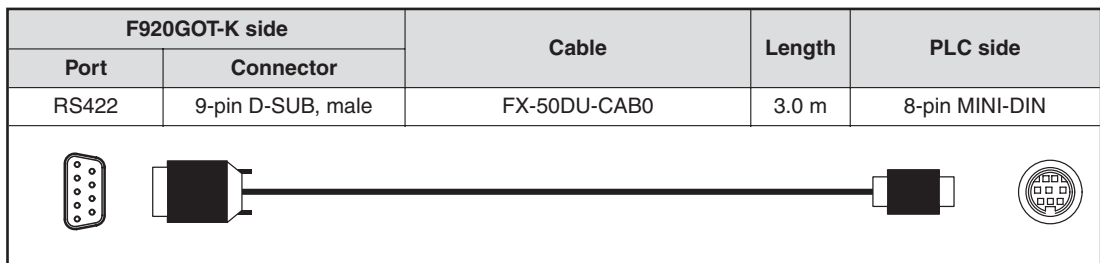

Connection to the programming port of a A or QnA series CPU

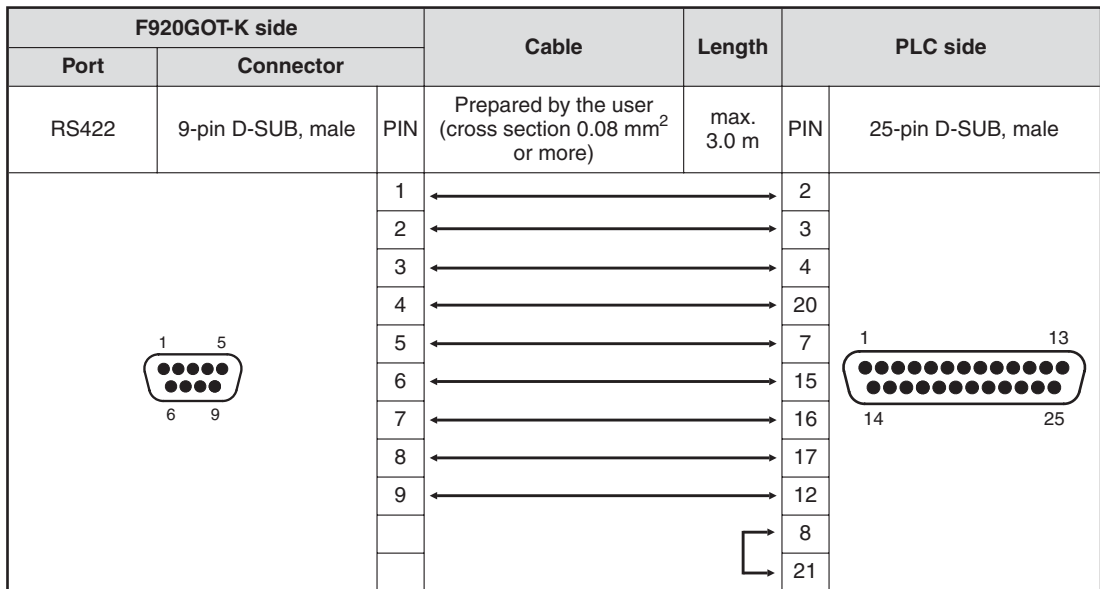

Connection to a CPU of the MELSEC System Q

The RS232C port of the GOT is used to connect a F920GOT-K with the programming port of a Q series CPU:

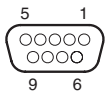
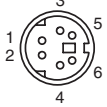
F920GOT-K side			Cable	Length	PLC side (Q series)		
Port	Connector				PIN	PIN	6-pin MINI-DIN
RS232C	9-pin D-SUB, female	PIN	Prepared by the user (cross section 0.08 mm ² or more)	max. 3.0 m	PIN	6-pin MINI-DIN	
			Shielding to the hood of the connectors				
			2	←————→			2
			3	←————→			1
			4	←————→			5
			5	←————→			3
			6	←————→			6
			7	←————→			
			8	←————→			
			9	←————→			4

When a personal computer (e.g. for data transfer) is connected to the RS232C port of the GOT, the RS422 port of the GOT is used to supply the F920GOT-K with power. Prepare a cable as shown below to connect the programming port (RS232C) of the CPU with the RS422 port of the GOT. Please refer also to section 6.1 for further information about data transfer.

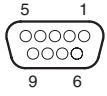
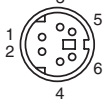
F920GOT-K side			Cable	Length	PLC side (Q series)	
Port	Connector				PIN	PIN
RS422	9-pin D-SUB, female	PIN	Prepared by the user (cross section 0.08 mm ² or more).	max. 3.0 m	PIN	6-pin MINI-DIN
			5	←————→	3	
			9	←————→	4	
						

Connection to PLCs of third party manufacturers

A F920GOT-K can not be connected to other logic controllers than the MELSEC FX, A, or QnA series or the MELSEC System Q from Mitsubishi Electric.

Connection to the programming port of a A or QnA series CPU

F930GOT-K side		Cable	Length	Verbindung zur SPS
Port	Connector			
RS422	9-pin D-SUB, male	FX-40DU-CAB/EN	3.0 m	25-pin D-SUB, male

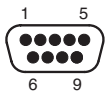

Connection to the interface modules AJ71UC24, AJ71QC24N, A1SJ71UC24-R4, A1SJ71QC24, and QJ71C24

F930GOT-K side			Cable	Length	PLC side (interface module)		
Port	Connector				Signal		
RS422	9-pin D-SUB, male	PIN	Prepared by the user	max. 30 m	Signal		
			Shielding to the hood of the connectors			Terminal block of the interface module	
			1	←	→		RXD+ (RDA)
			6	←	→		RXD- (RDB)
			2	←	→		TXD+ (SDA)
			7	←	→		TXD- (SDB)
			5	←	→		SG (GND)

Connection to an interface module AJ71QC24-R4

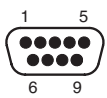
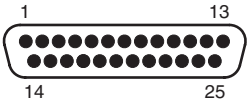
F930GOT-K side			Cable	Length	AJ71QC24-R4		
Port	Connector				PIN		
RS422	9-pin D-SUB, male	PIN	Prepared by the user	max. 30 m	PIN	25-pin D-SUB, male	
			Shielding to the hood of the connectors				
			1	←	→		2
			6	←	→		15
			2	←	→		3
			7	←	→		16
			5	←	→		8
			21				

Connection to the interface modules AJ71C21-S1, AJ71UC24, AJ71UC24-S2, AJ71QC24N-R2, and AJ71QC24N

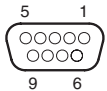
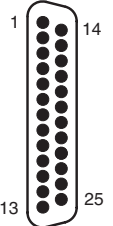
F930GOT-K side			Cable	Length	PLC side (interface module)			
Port	Connector				PIN	Signal	25-pin D-SUB, male	
RS232C	9-pin D-SUB, male	PIN	Prepared by the user	max. 15 m	PIN	Signal	25-pin D-SUB, male	
			Connect the shield at the PLC side only		Hood			
			2	←	→	2		SD (TXD)
			3	←	→	3		RD (RXD)
			7	←	→	4		RS (RTS)
			8	←	→	5		CS (CTS)
			6	←	→	20		ER (DTR)
			5	←	→	7		SG (GND)
			4	←	→	6		DR (DSR)

Connection to the interface modules A1SJ71UC24-R2, A1SJ71C24-PRF, A1SJ71UC24-R2-S2, A1SJ71QC24(-R2), and QJ71C24(-R2)

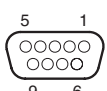
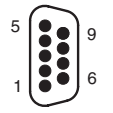
F930GOT-K side			Cable	Length	PLC side (interface module)			
Port	Connector				PIN	Signal	9-pin D-SUB, male	
RS232C	9-pin D-SUB, female	PIN	Prepared by the user	max. 15 m	PIN	Signal	9-pin D-SUB, male	
			Connect the shield at the PLC side only		Hood			
			2	←	→	3		SD (TXD)
			3	←	→	2		RD (RXD)
			4	←	→	6		DR (DSR)
			5	←	→	5		SG (GND)
			6	←	→	4		ER (DTR)
			7	←	→	7		RS (RTS)
			8	←	→	8		CS (CTS)

Connection to a CPU of the MELSEC System Q

F930GOT-K side		Cable	Length	PLC side
Port	Connector			
RS232C	9-pin D-SUB, female	QC30R2	3.0 m	6-pin MINI-DIN
				

Connection to PLCs of third party manufacturers

For further information on the connection of the operation terminals to logic controllers of third party manufacturers or e.g. frequency converters from Mitsubishi Electric please refer to the hardware manual of the GOT F900 series (connection).

5.2 Connection to a Personal Computer

For the transfer of the user screens to the operation terminal, connect a PC or a notebook computer (with the required software installed) to the RS232C port of the GOT.

Anschluss am F920GOT/F930GOT		Cable	Length	PC side
Port	Connector			
RS232C	9-pin D-SUB, female	FX-232-CAB1	3.0 m	9-pin D-SUB, female

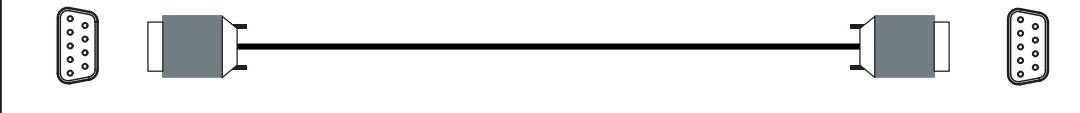

5.3 Wiring of the Power Supply (F930GOT-K)

Please use wires with a cross section of at least 0,75 mm² for the power supply . Install a fuse of 2 A in the power line.

If the GOT is connected to a PLC of the MELSEC FX series, the service power supply of the PLC can be used to supply the GOT. Please make sure that the current consumption of all connected devices such as GOT, extension blocks or special function modules is within the capacity of the service power supply. If the total current exceeds the capacity of the service power supply, use an external power supply (24 V DC) to power the GOT.

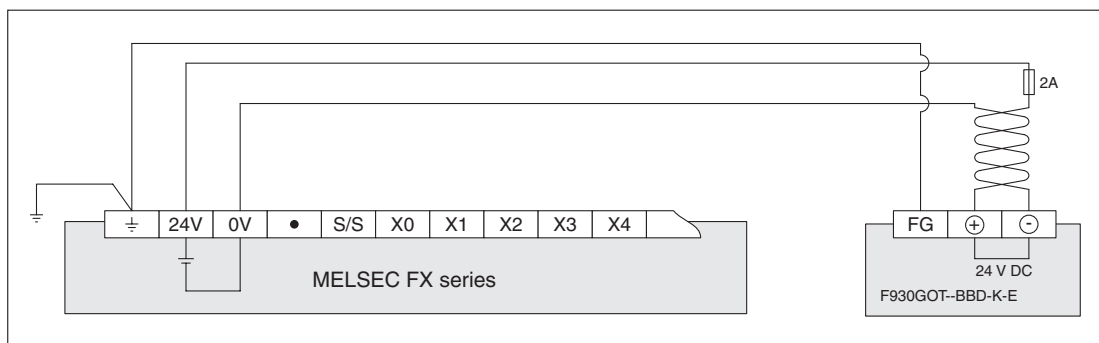

When the GOT is connected to an external power supply, ground the GOT and the PLC separately:

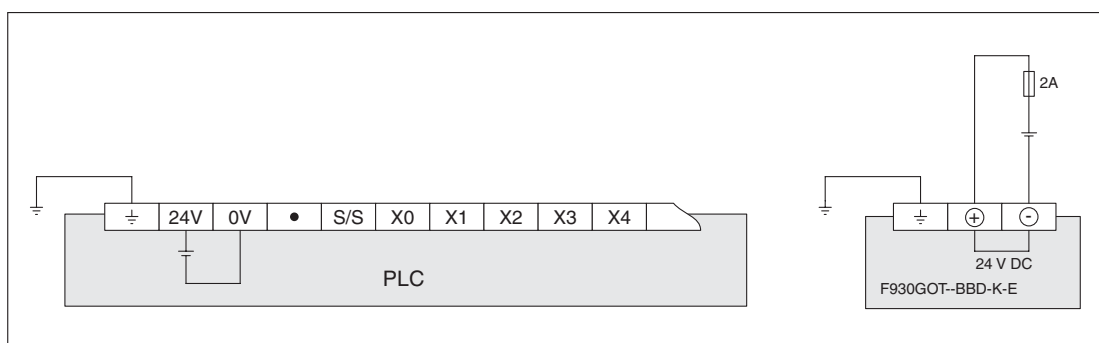

6 Start Up

- ① Make all connection required as shown in chapter 5.
- ② Turn on the power of the GOT.
- ③ Check the display. On the system screen „SET-UP MODE“ you can adjust the brightness of the screen („LCD CONTRAST“).
- ④ Set the required mode and the type of the connected PLC on the „SET-UP MODE“ screen. If this setting is not correct, communication between GOT and PLC is not possible.
- ⑤ Transfer the user screens to the GOT.

NOTE

If the PLC has already communicated with the GOT via the RS232C port, the port for the data transfer has to be selected manually:
Select „DATA TRANSFER“ in the „OTHER MODE“ screen.

6.1 Data Transfer to the F920GOT

The voltage (5 V DC) to power the F920GOT-BBD5-K-E is supplied via the communication ports. Therefore during the transfer of screen data using the RS232C port a PLC must be connected to the RS422 port to power the GOT.

If the F920GOT is connected to a PLC of the MELSEC FX, AnU, or QnA series:

There is no need to change the configuration. Connect a PC to the RS232C port of the GOT, make sure the power supply of the PLC is still switched on and start the data transfer.

If the F920GOT is connected to a PLC of the MELSEC System Q:

The RS232C port of the GOT is used for communication with a System Q CPU. During data transfer however, when the RS232C port is occupied by a PC, use the RS422 port of the GOT to supply the F920GOT-K with power from the PLC. Prepare a cable as shown in the lower figure on page 17.

For data transfer please follow the procedure given below:

- ① Switch off the power supply of the PLC.
- ② Remove the cable connecting the RS232C port of the GOT and the programming port of the System Q CPU.
- ③ Connect the PC and the GOT using the cable FX-232-CAB1.
- ④ Use the power supply cable shown on page 17 to connect the RS422 port of the GOT with the programming port of the System Q CPU.
- ⑤ Switch on the power supply of the PLC (and thereby the GOT), select „DATA TRANSFER“, in the „OTHER MODE“ screen and transfer the data to the GOT.
- ⑥ When the data transfer is finished, switch off the PLC, remove the power supply cable and make a connection between the RS232C port of the GOT and the programming port of the CPU using the cable shown in the upper figure on page 17.

7 Maintenance

**DANGER:**

Always switch off the power supply of the GOT before starting the replacement of the battery.

7.1 Replacement of the battery (F930GOT-K only)

When the voltage of the battery drops, an interface device (system information) in the connected PLC turns on. The device is allocated by the screen design software. Check this device in the program of the PLC and use it for instance to control a lamp so that the voltage drop can be monitored outside the GOT. For further information on the interface devices (FX-PCS/DU-WIN-E) or system informations (GT-Designer) please refer to the manuals of the screen design software.

NOTE

For approximately one month after the control device for battery voltage turns on, the battery backs up the alarm history, sampled data, and the clock. Screen data is stored in the flash memory. Even if the battery is totally worn out, the screen data remains stored.

Procedure for the replacement of the battery:

- ① Turn off the power supply of the GOT.
- ② Remove the cover of the battery holder.
- ③ Remove the battery from the battery holder and disconnect the battery.
- ④ Connect a new battery within 30 seconds.
- ⑤ Insert the new battery into the battery holder and attach the cover.
- ⑥ Turn on the power supply of the GOT.

HEADQUARTERS

MITSUBISHI ELECTRIC EUROPE
EUROPE B.V.
German Branch
Gothaer Straße 8
D-40880 Ratingen
Phone: +49 (0) 2102 / 486-0
Fax: +49 (0) 2102 / 486-1120
e mail: megfamail@meg.mee.com

MITSUBISHI ELECTRIC FRANCE
EUROPE B.V.
French Branch
25, Boulevard des Bouvets
F-92741 Nanterre Cedex
Phone: +33 1 55 68 55 68
Fax: +33 1 55 68 56 85
e mail: factoryautomation@framee.com

MITSUBISHI ELECTRIC IRELAND
EUROPE B.V.
Irish Branch
Westgate Business Park, Ballymount
IRL-Dublin 24
Phone: +353 (0) 1 / 419 88 00
Fax: +353 (0) 1 / 419 88 90
e mail: sales.info@meir.mee.com

MITSUBISHI ELECTRIC ITALY
EUROPE B.V.
Italian Branch
Via Paracelso 12
I-20041 Agrate Brianza (MI)
Phone: +39 039 6053 1
Fax: +39 039 6053 312
e mail: factoryautomation@it.mee.com

MITSUBISHI ELECTRIC SPAIN
EUROPE B.V.
Spanish Branch
Carretera de Rubí 76-80
E-08190 Sant Cugat del Vallés
Phone: +34 9 3 / 565 3131
Fax: +34 9 3 / 589 2948
e mail: industrial@sp.mee.com

MITSUBISHI ELECTRIC UK
EUROPE B.V.
UK Branch
Travellers Lane
GB-Hatfield Herts. AL10 8 XB
Phone: +44 (0) 1707 / 27 61 00
Fax: +44 (0) 1707 / 27 86 95
e mail: automation@meuk.mee.com

MITSUBISHI ELECTRIC CORPORATION JAPAN
Office Tower "Z" 14 F
8-12,1 chome, Harumi Chuo-Ku
Tokyo 104-6212
Phone: +81 3 6221 6060
Fax: +81 3 6221 6075

MITSUBISHI ELECTRIC AUTOMATION USA
500 Corporate Woods Parkway
Vernon Hills, IL 60061
Phone: +1 847 / 478 21 00
Fax: +1 847 / 478 22 83

MIDDLE EAST REPRESENTATIVE

Ilan & Gavish Ltd. ISRAEL
Automation Service
24 Shenkar St., Kiryat Arie
IL-49001 Petah-Tiqva
Phone: +972 (0) 3 / 922 18 24
Fax: +972 (0) 3 / 924 07 61
e mail: iandg@internet-zahav.net

EUROPEAN REPRESENTATIVES

GEVA AUSTRIA
Wiener Straße 89
AT-2500 Baden
Phone: +43 (0) 2252 / 85 55 20
Fax: +43 (0) 2252 / 488 60
e mail: office@geva.at

TEHNIKON BELARUS
Oktjabrskaya 16/5, Ap 704
BY-220030 Minsk
Phone: +375 (0)17 / 22 75 704
Fax: +375 (0)17 / 22 76 669
e mail: tehnikon@belsonet.net

Getronics b.v. BELGIUM
Control Systems
Pontbeeklaan 43
B-1731 Asse-Zellik
Phone: +32 (0) 2 / 467 17 51
Fax: +32 (0) 2 / 467 17 45
e mail: infoautomation@getronics.com

TELECON CO. BULGARIA
4, A. Ljapchev Blvd.
BG-1756 Sofia
Phone: +359 (0) 2 / 97 44 05 8
Fax: +359 (0) 2 / 97 44 06 1
e mail: —

INEA CR d.o.o. CROATIA
Losinjska 4 a
HR-10000 Zagreb
Phone: +385 (0) 1 / 36 940-01
Fax: +385 (0) 1 / 36 940-03
e mail: inea@inea.hr

AutoCont CZECH REPUBLIC
Control Systems s.r.o.
Nemocnicni 12
CZ-702 00 Ostrava 2
Phone: +420 59 / 6152 111
Fax: +420 59 / 6152 562
e mail: consys@autocont.cz

louis poulsen DENMARK
industri & automation
Geminivej 32
DK-2670 Greve
Phone: +45 (0) 70 / 10 15 35
Fax: +45 (0) 43 / 95 95 91
e mail: lpia@lpmail.com

UTU Elektrotehnika AS ESTONIA
Pärnu mnt.160i
EE-11317 Tallinn
Phone: +372 (0) 6 / 51 72 80
Fax: +372 (0) 6 / 51 72 88
e mail: utu@utu.ee

Beijer Electronics OY FINLAND
Ansatie 6a
FIN-01740 Vantaa
Phone: +358 (0) 9 / 886 77 500
Fax: +358 (0) 9 / 886 77 555
e mail: info@beijer.fi

UTECO A.B.E.E. GREECE
5, Mavrogenous Str.
GR-18542 Piraeus
Phone: +302 (0) 10 / 42 10 050
Fax: +302 (0) 10 / 42 12 033
e mail: sales@uteco.gr

Meltrade Automatika Kft. HUNGARY
55, Harmat St.
HU-1105 Budapest
Phone: +36 (0)1 / 2605 602
Fax: +36 (0)1 / 2605 602
e mail: office@meltrade.hu

SIA POWEL LATVIA
Lienes iela 28
LV-1009 Riga
Phone: +371 784 / 22 80
Fax: +371 784 / 22 81
e mail: utu@utu.lv

EUROPEAN REPRESENTATIVES

UAB UTU POWEL LITHUANIA
Savanoriu pr. 187
LT-2053 Vilnius
Phone: +370 (0) 52323-101
Fax: +370 (0) 52322-980
e mail: powel@utu.lt

INTEHSIS SRL MOLDOVA
Cuza-Voda 36/1-81
MD-2061 Chisinau
Phone: +373 (0)2 / 562 263
Fax: +373 (0)2 / 562 263
e mail: intehsis@mdl.net

Getronics b.v. NETHERLANDS
Control Systems
Donauweg 2 B
NL-1043 AJ Amsterdam
Phone: +31 (0) 20 / 587 67 00
Fax: +31 (0) 20 / 587 68 39
e mail: info.gia@getronics.com

Beijer Electronics AS NORWAY
Teglværksveien 1
N-3002 Drammen
Phone: +47 (0) 32 / 24 30 00
Fax: +47 (0) 32 / 84 85 77
e mail: info@beijer.no

MPL Technology Sp. z o.o. POLAND
ul. Sliczna 36
PL-31-444 Kraków
Phone: +48 (0) 12 / 632 28 85
Fax: +48 (0) 12 / 632 47 82
e mail: krakow@mpl.pl

Sirius Trading & Services srl ROMANIA
Str. Biharia No. 67-77
RO-013981 Bucuresti 1
Phone: +40 (0) 21 / 201 1146
Fax: +40 (0) 21 / 201 1148
e mail: sirius@siriustrading.ro

INEA SR d.o.o. SERBIA AND MONTENEGRO
Karadjordjeva 12/260
SCG-113000 Smederevo
Phone: +381 (0)26/ 617 - 163
Telefax: +381 (0)26/ 617 - 163
E-Mail: inea_sr@verat.net

INEA d.o.o. SLOVENIA
Stegne 11
SI-1000 Ljubljana
Phone: +386 (0) 1-513 8100
Fax: +386 (0) 1-513 8170
e mail: inea@inea.si

Beijer Electronics AB SWEDEN
Box 426
S-20124 Malmö
Phone: +46 (0) 40 / 35 86 00
Fax: +46 (0) 40 / 35 86 02
e mail: info@beijer.se

ECONOTEC AG SWITZERLAND
Postfach 282
CH-8309 Nürensdorf
Phone: +41 (0) 1 / 838 48 11
Fax: +41 (0) 1 / 838 48 12
e mail: info@econotec.ch

GTS TURKEY
Darülacez Cad. No. 43 Kat. 2
TR-80270 Okmeydani-Istanbul
Phone: +90 (0) 212 / 320 1640
Fax: +90 (0) 212 / 320 1649
e mail: gts@turk.net

CSC Automation Ltd. UKRAINE
15, M. Raskova St., Fl. 10, Office 1010
UA-02002 Kiev
Phone: +380 (0) 44 / 238-83-16
Fax: +380 (0) 44 / 238-83-17
e mail: csc-a@csc-a.kiev.ua

EURASIAN REPRESENTATIVES

Avtomatika Sever Ltd. RUSSIA
Lva Tolstogo St. 7, Off. 311
RU-197376 St Petersburg
Phone: +7 812 / 11 83 238
Fax: +7 812 / 11 83 239
e mail: as@avtsev.spb.ru

CONSYS RUSSIA
Promyshlennaya St. 42
RU-198099 St Petersburg
Phone: +7 812 / 325 36 53
Fax: +7 812 / 147 20 55
e mail: consys@consys.spb.ru

Electrotechnical Systems Siberia RUSSIA
Partizanskaya St. 27, Office 306
RU-121355 Moscow
Phone: +7 095 / 416-4321
Fax: +7 095 / 416-4321
e mail: info@eltechsystems.ru

Electrotechnical Systems Siberia RUSSIA
Shetinkina St. 33, Office 116
RU-630088 Novosibirsk
Phone: +7 3832 / 22-03-05
Fax: +7 3832 / 22-03-05
e mail: info@eltechsystems.ru

Elektrostyle RUSSIA
ul. Garschina 11
RU-140070 Moscow
Phone: +7 095 / 514 9316
Fax: +7 095 / 514 9317
e mail: info@estl.ru

Elektrostyle RUSSIA
Krasnij Prospekt 220-1
Office No. 312
RU-630049 Novosibirsk
Phone: +7 3832 / 10 66 18
Fax: +7 3832 / 10 66 26
e mail: info@estl.ru

ICOS RUSSIA
Industrial Computer Systems Zao
Ryazanskij Prospekt 8a, Office 100
RU-109428 Moscow
Phone: +7 095 / 232 - 0207
Fax: +7 095 / 232 - 0327
e mail: mail@icos.ru

NPP Uralelektra RUSSIA
ul. Sverdlova 11a
RU-620027 Ekaterinburg
Phone: +7 34 32 / 53 27 45
Fax: +7 34 32 / 53 27 45
e mail: elektra@etel.ru

STC Drive Technique RUSSIA
ul. Bajkalskaja 239, Office 2 - 23
RU-664075 Irkutsk
Phone: +7 3952 / 24 38 16
Fax: +7 3952 / 23 02 98
e mail: privod@irk.ru

STC Drive Technique RUSSIA
Poslannikov Per. 9, str.1
RU-107005 Moscow
Phone: +7 095 / 790-72-10
Fax: +7 095 / 790-72-12
e mail: info@privod.ru

AFRICAN REPRESENTATIVE

CBI Ltd. SOUTH AFRICA
Private Bag 2016
ZA-1600 Isando
Phone: +27 (0) 11 / 928 2000