



Absolute multiturn encoders

- ▶ 25 bit with synchro-, clamping- or stator flange
- ▶ IP 66 at housing, IP 64 at shaft inlet
- ▶ 58 mm diameter
- ▶ 9...36 Vdc
- ▶ Available with 6 or 10 mm stub-shaft or 12 mm hollow-shaft



684

685

684 Hollow shaft

ELECTRICAL SPECIFICATION

Supply voltage +EV	9-36V	
	Polarity protected	
Current consumption at no load	2W @ 24V Max 3W	
Power on delay	600ms	
Resolution		
Singleturn	13 bit, 8192 positions / revolution	
Multiturn	12 bit, 4096 distinguishable revolutions	
Accuracy	± ½ LSB	
Incremental track	Sinusoidal 1Vpp	
Resolution	512 ± 60"	
Outputs, Serial	SSI	
Code (programmable)	Gray, Binary (Standard/Tannenbaum)	
CLOCK input	RS-422	
DATA output	RS-422	
Frequency range CLOCK	100kHz - 1MHz	
Update frequency	2kHz	
Output delay	0,5ms	
Error signal U _{as/}		
High, OK	>+EV - 3V	
Low, Warning	< 0,4V	min 2s
Inputs	PRESET 1, 2	DIRECTION
U _{high}	> +EV x 0,6	> +EV x 0,6
U _{low}	< +EV x 0,25	< +EV x 0,25
Active	High	High (CCW)
Not connected	Low	Low (CW)
Delay	1 ms	1 ms
PC communication	RS-232	Max 10m cable

ACCESSORIES

Mating connector	Part. No. 01209085 (17 pin EML)
PC software	
English	Part. No. 01290013
German	Part. No. 01290022
Programming cable	Part. No. 01209052
Mounting bracket	See datasheets for accessories
Mounting kit	
Bearing box	
Couplings	

DESCRIPTION PROGRAMMABLE SSI

Simple and rapid serial point-to-point communication. The absolute positional value (DATA) is sent synchronously with a CLOCK signal from the receiver electronics.

The encoder can be programmed and adapted for the application with the help of PC software. The following functions are available:

- **Scaling.** The resolution of the encoder as it revolves and the number of revolutions can be scaled as required.
- **Preset.** Two independent presets can be programmed, for example for reset and operating compensation.
- **Direction.** Rising code for a clockwise or counter clockwise direction of rotation can be selected.
- **Code for positional data.** Optional if it wished to have positional data such as Gray or binary code.
- **Data format.** It is possible to stipulate how the position information is clocked out, standard right-handed or Tannenbaum format.

With PC communication it is also possible to obtain operating and identity information from the encoder.

CONNECTION

Function	17 pin EML
+E Volt (U _p)	7
0 Volt (U _n)	10
Clock	8
Clock	9
Data	14
Data	17
Internal screen	11
<u>1</u>	12
1	13
<u>2</u>	15
2	16
PRESET 1	5
PRESET 2	6
DIRECTION	2
U _{as/}	3
RS-232 TXD	1
RS-232 RXD	4

684 / 685 Programmable SSI

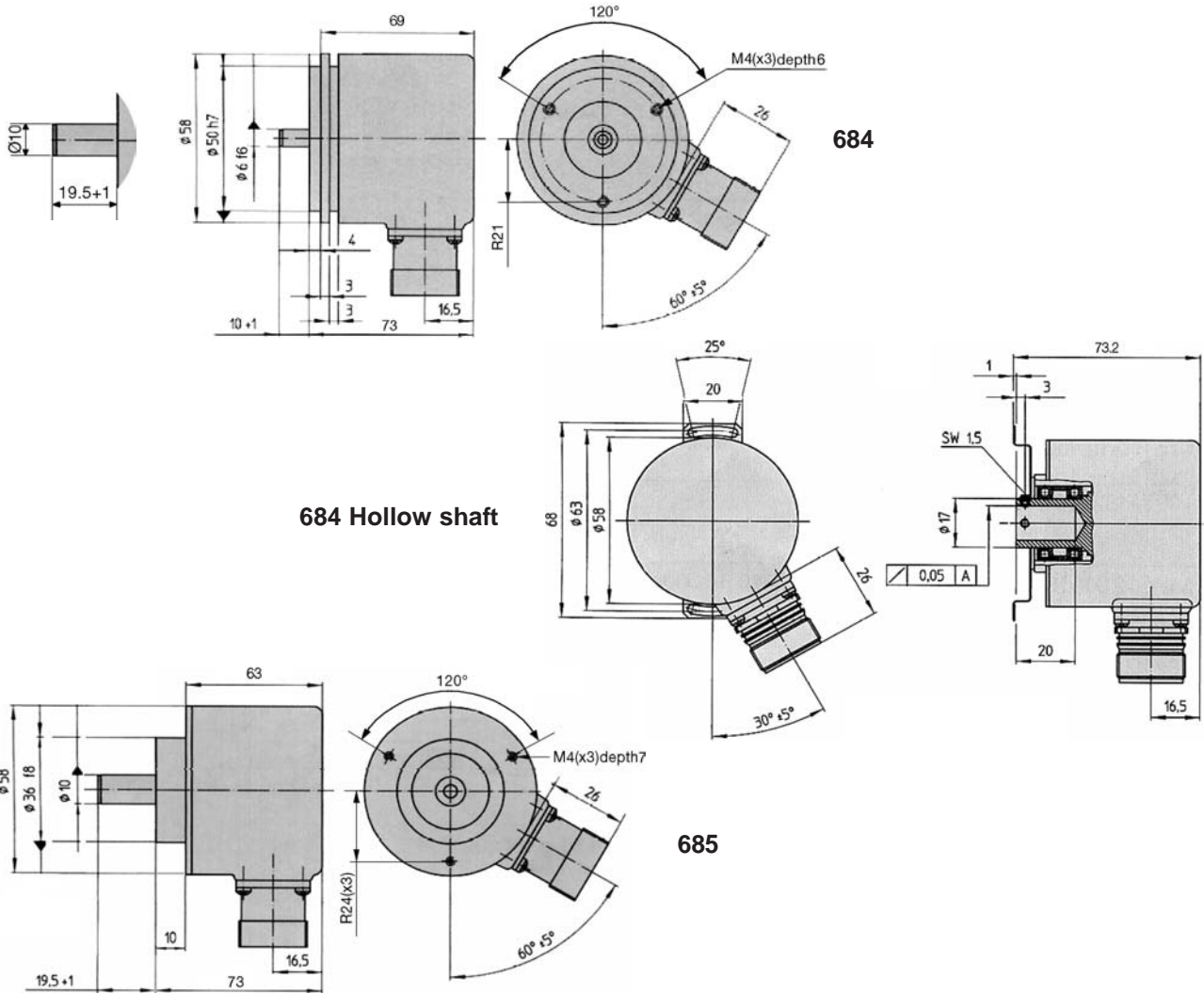

684 Hollow shaft

685

MECHANICAL SPECIFICATION

Shaft, Stainless steel	Stub-shaft Ø 6, 10mm	Hollow-shaft Ø 12 mm
Moment of inertia	$3,8 \times 10^{-6} \text{ kgm}^2$	$4,6 \times 10^{-6} \text{ kgm}^2$
Load max		
Radial	60N	20N
Axial	40N	10N
Speed max	6000 rpm	
Code disc	Glass disc	
Temperature		
Operating	-20°C ... +70°C	
Storage	-30°C ... +80°C	
Housing	Aluminum	
Weight	Approx. 300g	
Protection class	IP 66 according to IEC 529	
Shaft inlet	IP 64 according to IEC 529	
Vibration	<100m/s ² (50...2000 Hz)	
Shock	<1000m/s ² (11ms)	
Connection	17-pin radial EML	

ORDERING INFORMATION

Available models

684 302281

25 Bit multiturn with 6mm stub-shaft and synchro flange

684 304281

25 Bit multiturn with 10mm stub-shaft and synchro flange

684 305281

25 Bit multiturn with 12mm hollow-shaft and stator coupling

685 304281

25 Bit multiturn with 10mm stub-shaft and clamping flange

Leine&Linde ISO 9001 / ISO 14001 certified

Leine&Linde AB, Box 8, SE-645 21 Strängnäs, Sweden. Olivehällsvägen 8.
Phone: +46 (0)152 265 00. Fax: +46 (0)152 265 05. E-mail: info@leinelinde.se

04-06-17 PS. Specifications can be changed without prior notice.